

7

6

5

4

3

2

1

### Gas Train Detail

Item	Req	Description
1	2	Main Gas Shutoff Valve
2	1	Gas Valve Actuator (w/o POC)
3	1	Gas Valve Regulating Actuator (w/ POC)
4	1	Gas Pilot Valve
5	1	Pilot Pressure Regulator *
6	1	Pilot Pressure Gauge
7	1	Low Gas Pressure Switch MR
8	1	High Gas Pressure Switch MR
9	1	Pilot Gas Cock
10	1	Butterfly Valve
11	2	Test Cock

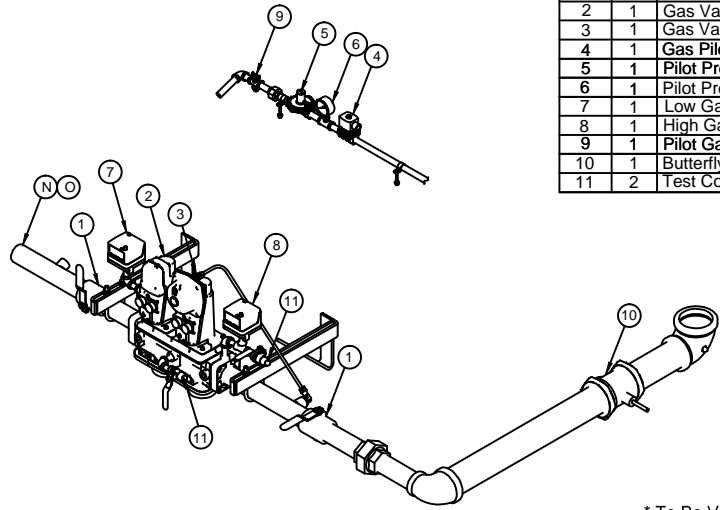

\* To Be Vented To Safe Point Of Discharge

### Oil Piping Detail

Item	Req	Description
1	2	Solenoid Valve
2	2	Relief Valve
3	1	Fuel Oil Controller
4	1	Low Oil Pressure Switch
5	2	Pressure Gauge
6	1	Fuel Oil Filter

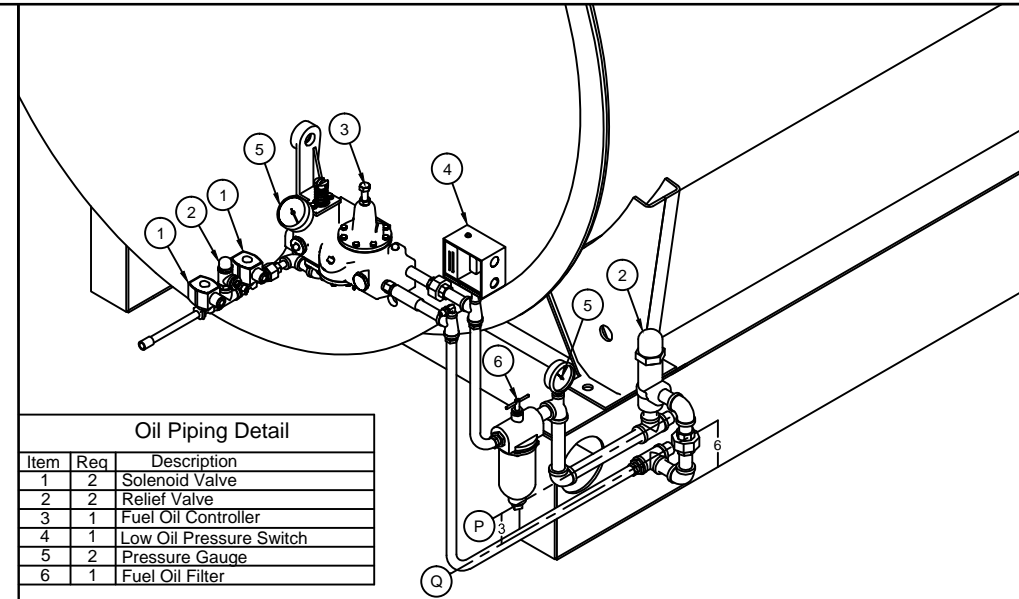

### Bottom Blowdown Detail

Item	Req	Description
1	1	Slow Opening Blowdown Valve - Tecval VP250 - SO 1.5 NPT
2	2	Quick Opening Blowdown Valve - Tecval VP250 - QO 1.5 NPT

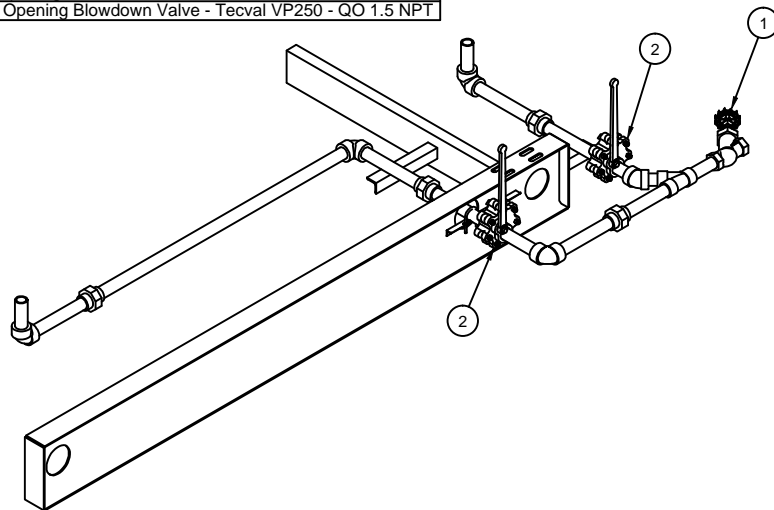

### Surface Blowoff Detail

Item	Req	Description
1	1	Gate Valve .75 NPT
2	1	Electrode Probe
3	1	Advantage Motorized Valve .5 NPT
4	2	Gate Valve .25 NPT
5	1	Flowcontrol Valve .5 NPT
6	1	Sample Cooler

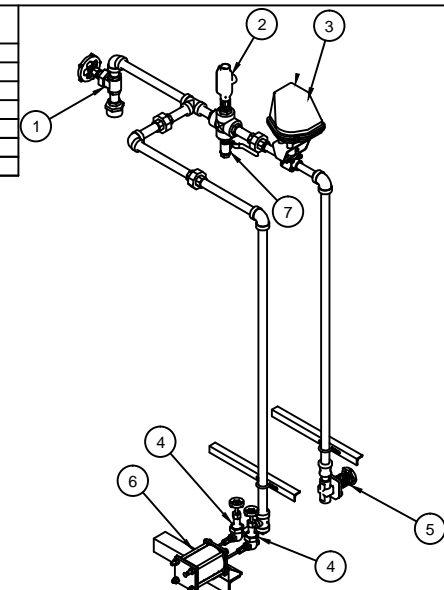

### Ship Loose

These Items Are Shipped Loose For Installation By Others

Safety Valve - (2) Set At 150#

Oil Pump Set - (1) TUTHILL 1LE-A 1/2 HP 115 GPH 1725 RPM

### Fuel Oil Pump Set - Tuthill

Model: 1LE-A Motor: 1/2 HP Capacity: 115 GPH

Notes  
 Normal Pump Operating Discharge Pressure 100 PSIG  
 Maximum Recommended Pump Suction 12 Inches Of Mercury  
 Pump Assemblies Include Suction Strainer, Magnetic Starter & Hand - Off Automatic Switch  
 Pump Set Is Shipped Loose For Installation Close To Oil Storage Tank  
 Oil Flow Can Be In Either Direction

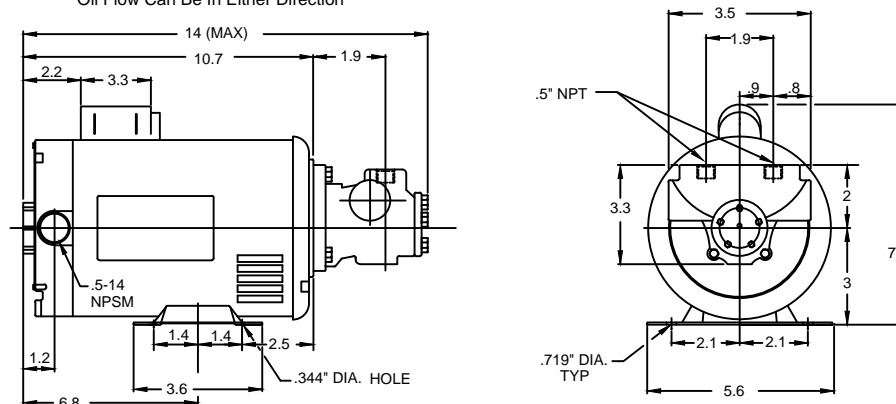

### CAUTION

DIMENSIONS SHOWN ARE APPROXIMATE AND SHOULD NOT BE USED IN RESTRICTIVE LAYOUTS OR TO PREFABRICATE ASSEMBLIES UNLESS CLEAVER-BROOKS HAS BEEN CONSULTED. IT IS STRONGLY RECOMMENDED THAT THE CUSTOMER REQUEST AS-BUILT CERTIFIED DRAWINGS FOR THESE CASES.

### WARNING

LIFTING LUGS PROVIDED ON THE VESSEL SHALL ONLY BE USED TO LIFT THE VESSEL WHEN IT IS DRY.

### WARNING

CHANGES, MODIFICATIONS OR ALTERATIONS ARE STRICTLY PROHIBITED.

CHANGES TO THIS DRAWING AND SUBSEQUENT MODIFICATION OF EQUIPMENT COULD RESULT IN DAMAGE TO THE EQUIPMENT AND/OR SERIOUS PERSONAL INJURY.

PRELIMINARY

DIMENSIONAL DIAGRAM

SIZE D

SHT 02 OF 02

SCALE N.T.S.

DATE 12/21/11

DRAWN H L J

CHECKED BY M S T

# CleaverBrooks

MODEL	FUEL SIZE	SIZE	PRESSURE	CAPACITY
CBEX ELITE	200	200	150ST	
460	3	60	3	N/A
DRWG. NO. CBEX ELITE 200 HP 150				

THIS DRAWING IS PROPERTY OF CLEAVER-BROOKS DIVISION. IT IS SUBJECT TO CHANGE WITHOUT NOTICE, AND IS NOT TO BE COPIED OR USED IN ANY WAY DETRIMENTAL TO THE COMPANY.

REVISIONS

00