

MAJOR COMPONENTS	
1	Control Panel
2	Entrance Panel
3	Blower Motor - 10 HP
4	Air Compressor - 5 HP
5	Combustion Safeguard Control - CB780E
6	Flame Scanner- Infrared
7	Pressure Control - Operating Limit
8	Pressure Control - High Limit (Manual Reset)
9	Pressure Control - Modulating
10	Main Low Water Column - Levelmaster II
11	Auxiliary Low Water Cutoff - Warrick 3C-2
12	Steam Gauge
13	N/A
14	Stack Thermometer
15	Safety Valve (2) Set @ 150#
16	Gas Train
17	Fuel Oil Piping Terminal
18	Fuel Oil Pump Assembly
19	Manway 12" x 16"
20	N/A

SERVICE CONNECTIONS	
A	Electric - Main Power Supply- 460 / 3 / 60
B	N/A
C	Exhaust Vent Pipe - 20" OD
D	Vent Flange (See Detail)
E	Steam Outlet - 6" 300# R.F. Flange
F	N/A
G	N/A
H	Feedwater - (2) 2.0 NPT
I	Bottom Blowdown - (2) 1.5 NPT
J	Water Column Blowdown - 0.75 NPT
K	Gauge Glass Blowdown - 0.25 NPT
L	Surface Blowoff - 1.0 NPT
M	N/A
N	Main Gas - 2.0
O	Minimum Inlet Gas Pressure Required is 41" w.c. Maximum Inlet Gas Pressure Required PSI: TBD Rating - 10,205 (cfh) MBtu
P	Oil Inlet - 0.75 NPT ( 75 PSI Required at Inlet) Rating - 72.9 gph
Q	Oil Outlet - 0.75 NPT
R	Chemical Feed - 1.0 NPT
S	Safety Valve - (1) Kunkle 6010GFE 1.25 x 1.5 FPT (Outlet)
T	Safety Valve - (1) Kunkle 6010HGE 1.5 x 2.0 FPT (Outlet)

NOTES

- \* Boiler is Designed and Constructed in Accordance with the ASME Boiler and Pressure Vessel Code - Section 1 High Pressure Boiler
- \* This Unit Complies with Insurance Underwriters Requirement for None Specified
- \* The Boiler Package is painted with High Temperature Light Blue Enamel
- \* The Burner Operation is Full Modulating
- \* The Boiler Burner Package Has A UL Label

This Boiler Is Provided with:

- Control Circuit Transformer
- Welded End Caps on Baserails

BOILER SPECIFICATIONS	
Boiler Designation - CBEX ELITE 200 250	
Design Pressure - 150 ST	
Design Rating - 250 hp	
Emissions - 60 ppm	
Fuel(s) - No. 2 Oil and Natural Gas	
Steam Capacity - 8,625 # stm/hr @212 deg F	
Fireside Heating Surface - 820 Sq. Ft.	
Dry Weight - 17,960 LB	
Normal Water Weight - 11,620 LB	
Gallons (Operating) - 1,393	
Code Compliance - N/A	

THIS DRAWING IS PROPERTY OF CLEAVER-BROOKS DIVISION. IT IS SUBJECT TO CHANGE WITHOUT NOTICE, AND IS NOT TO BE COPIED OR USED IN ANY WAY DETRIMENTAL TO THE COMPANY.

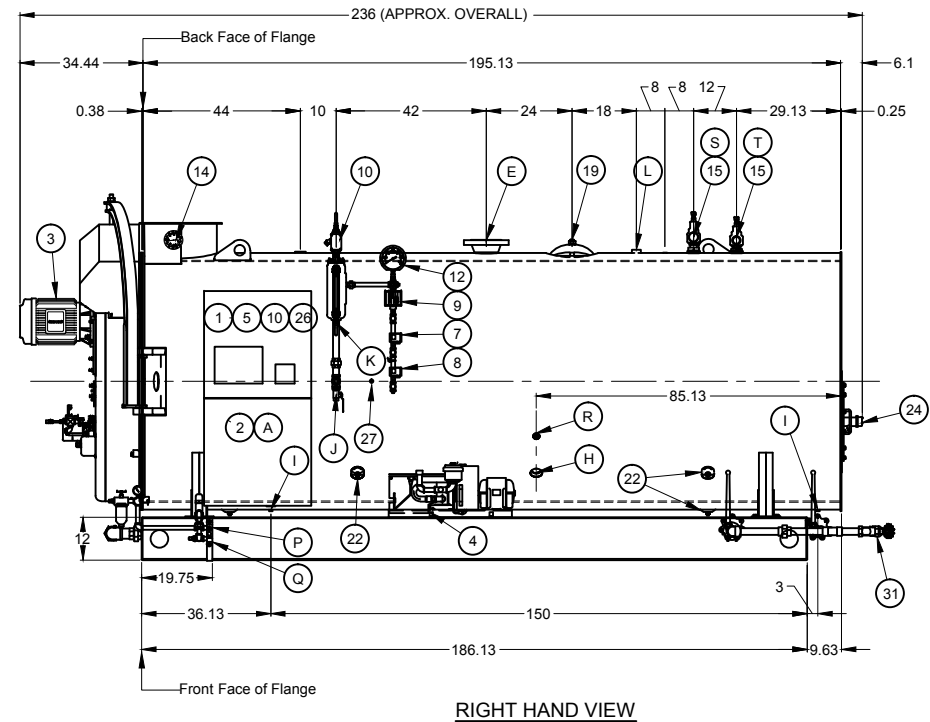
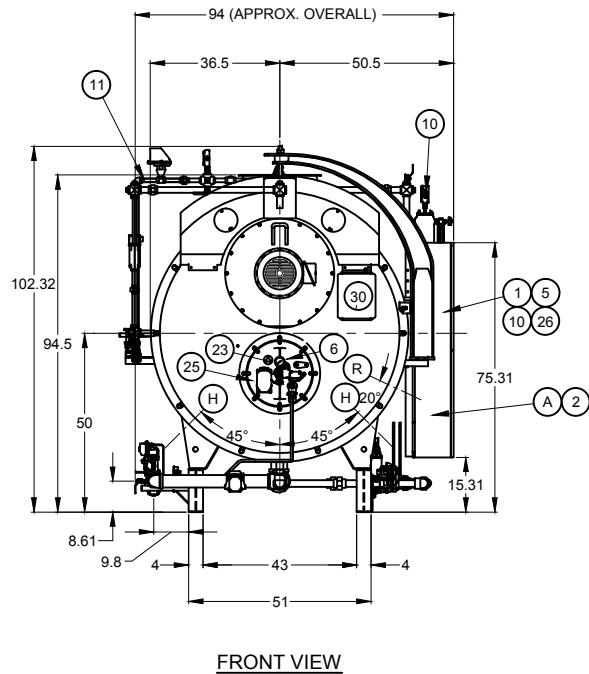
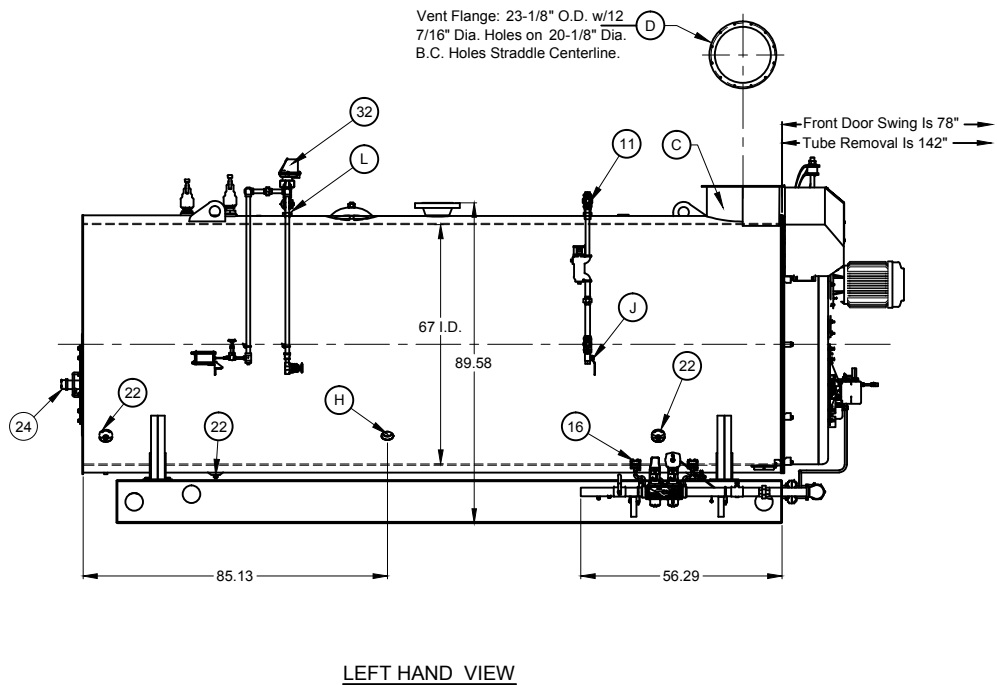

**CAUTION**

DIMENSIONS SHOWN ARE APPROXIMATE AND SHOULD NOT BE USED IN RESTRICTIVE LAYOUTS OR TO PREFABRICATE ASSEMBLIES UNLESS CLEAVER-BROOKS HAS BEEN CONSULTED. IT IS STRONGLY RECOMMENDED THAT THE CUSTOMER REQUEST AS-BUILT CERTIFIED DRAWINGS FOR THESE CASES.

**WARNING**

LIFTING LUGS PROVIDED ON THE VESSEL SHALL ONLY BE USED TO LIFT THE VESSEL WHEN IT IS DRY.

**WARNING**

CHANGES, MODIFICATIONS OR ALTERATIONS ARE STRICTLY PROHIBITED.  
CHANGES TO THIS DRAWING AND SUBSEQUENT MODIFICATION OF EQUIPMENT COULD RESULT IN DAMAGE TO THE EQUIPMENT AND/OR SERIOUS PERSONAL INJURY.

PRELIMINARY

DIMENSIONAL DIAGRAM

SIZE D

SHT 01 OF 02

SCALE N.T.S.  
DATE 12/21/11

DRAWN H L J

CHECKED BY M S T

**CleaverBrooks**

MODEL	200	250	150ST	CAPACITY
SIZE	3	60	3	N/A
PHASE		HERTZ	WIDE	INSURANCE

DRWG. NO. CBEX ELITE 250 HP 150 00